

Item	Description	Qty
A	Bracket, Passenger	1
B	Bracket, Driver	1
C	Rear Shock Brackets	2

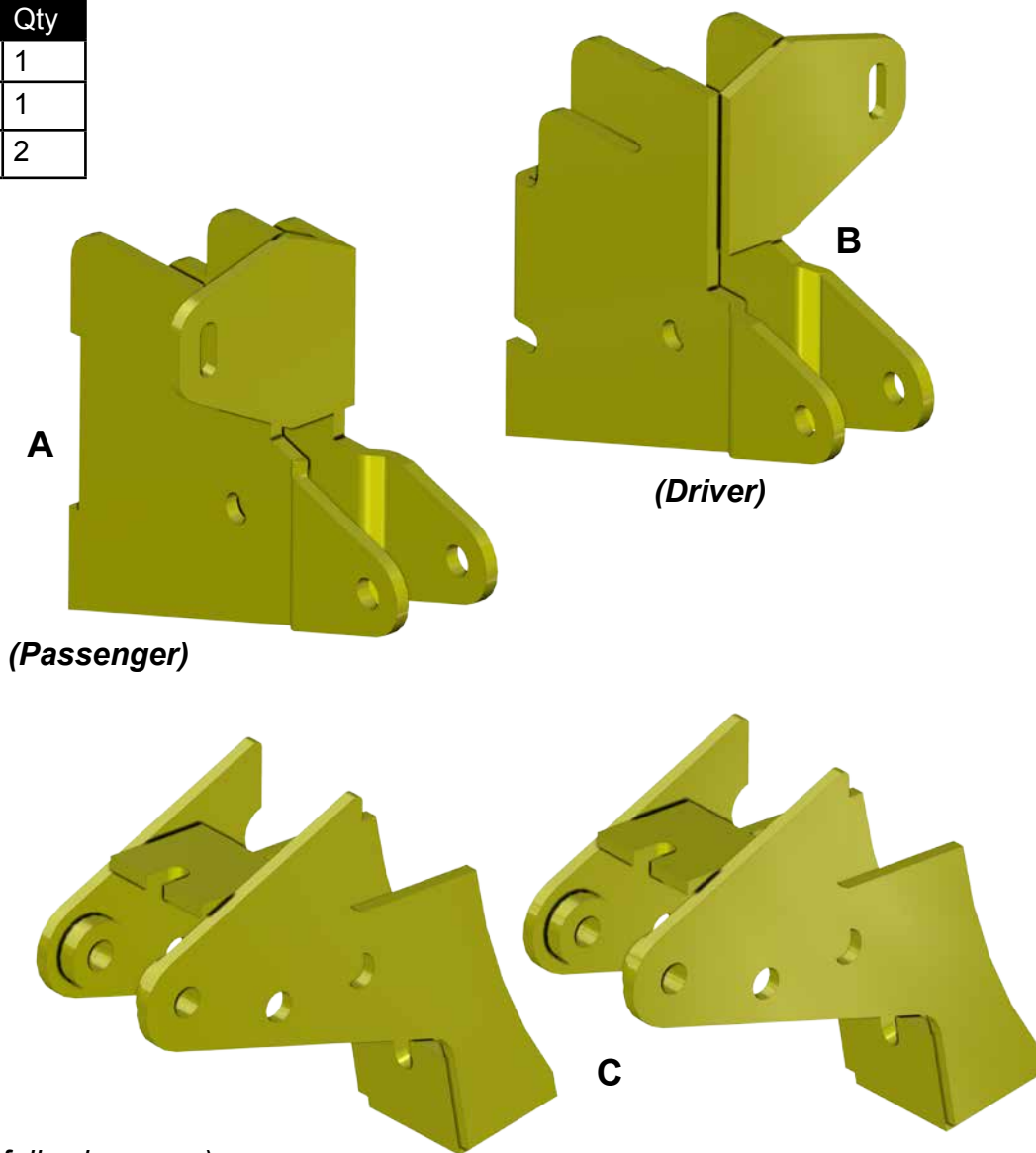

(kit contents continue on following page)

Need help with your installation?



sales@superatv.com



www.superatv.com



1-855-743-3427



8:00am - 9:00pm EST M-Th
 8:00am - 7:00pm EST Friday
 9:00am - 2:00pm EST Saturday

Read instructions and view illustrations before beginning.

*Thank You
 For Choosing*





(kit contents continued)

2x  M6-1.0 x 30mm Lg. FHCS

2x  M10-1.50 x 60mm Lg. FHCS

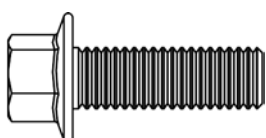
4x  M10-1.50 x 70mm Lg. FHCS

4x  M8-1.25 x 25mm Lg. FHCS

6x  M10-1.50 Nylock Nut

2x  M6-1.0 Nylock Nut

2x  M8-1.25 Nylock Nut

2x  M8-1.25 Clip Nut

IMPORTANT! For Commander X Models:

Disconnect Front Sway Bar from Lower A-Arms before beginning installation.
Reconnect when installation is complete and machine is on ground.

Liability Statement

SuperATV's® products are designed to best fit user's ATV/UTV under stock conditions. Adding, modifying, or fabricating any factory or aftermarket parts will void any warranty provided by SuperATV® and is not recommended. SuperATV's® products could interfere with other aftermarket accessories. If user has aftermarket products on machine, contact SuperATV® to verify that they will work together.

Although SuperATV® has thousands of satisfied customers, user should be aware that installing lift kits, long travel, or suspension kits, tires, etc. will change the ride of machine and may increase maintenance and part wear. Operating any off-road machine while, or after, consuming alcohol and/or drugs increases risk of bodily harm or death. No warranty or representation is made as to this product's ability to protect user from severe injury or death. SuperATV® urges operators and occupants to wear a helmet and appropriate riding gear at all times.

By purchasing and installing SuperATV® products, user agrees that should damages occur, SuperATV® will not be held responsible for loss of time, use, labor fees, replacement parts, or freight charges. SuperATV®, nor any 3rd party, will not be held responsible for any direct, indirect, incidental, special, or consequential damages that result from any product purchased from SuperATV®. The total liability of seller to user for all damages, losses, and causes of action, if any, shall not exceed the total purchase price paid for the product that gave rise to the claim.

SuperATV® will warranty only parts provided by SuperATV®. Any damage or problems with OEM housings, bearings, seals, or other manufacturers' products will not be covered by SuperATV®. SuperATV® parts and products are not warranted if item was not installed properly, misused, or modified.

Installing, adding, modifying, or fabricating any factory or aftermarket product to your ATV/UTV may violate certain local, state, and federal laws. Be advised that laws vary depending on town, city, county, state, etc. Use of certain products on public streets, roads, or highways may be in violation law. The Buyer is solely and exclusively legally and personally responsible for any violation of the law by the installation or use of the product. You must abide by all local, state, and federal laws, including but not limited to vehicle safety, traffic laws, and ordinances. It is your responsibility to know the laws and how they apply to you.

The Buyer is responsible to fully understand the capability and limitations of his/her vehicle according to manufacturer specifications, warnings and instructions and agrees to hold SuperATV® harmless from any damage resulting from failure to adhere to such specifications, warnings and/ or instructions. The Buyer is also responsible to obey all applicable federal, state, and local laws and ordinances when operating his/her vehicle while using this product, and the Buyer agrees to hold SuperATV® harmless from any violation thereof.

- **Keep all components removed from machine.**
- **Do not tighten hardware completely unless noted.**

Front Installation:

1. Raise front of machine off ground, secure with jack stands, and remove Wheels.
 - Disconnect end of Air Hose as shown in Fig. 1.
2. Install Bracket, Passenger (A) to Frame with M8-1.25 x 25mm Lg. FHCS and M8-1.25 Nylock Nut. See Fig. 2.
 - Secure Bracket, Passenger (A) to Frame with M6-1.0 x 30mm Lg. FHCS and M6-1.0 Nylock Nut. See Fig. 2a.
 - Use stock Shock hardware to secure Bracket to stock Shock mounting hole in Frame. See Fig. 2a.
 - Repeat steps for opposite side.
3. Install Shocks to Brackets (A)(B) with M10-1.50 x 60mm Lg. FHCS and M10-1.50 Nylock Nuts. See Fig. 2.
4. Tighten all hardware completely. Reinstall Wheels.



(illustrations continue on following pages)

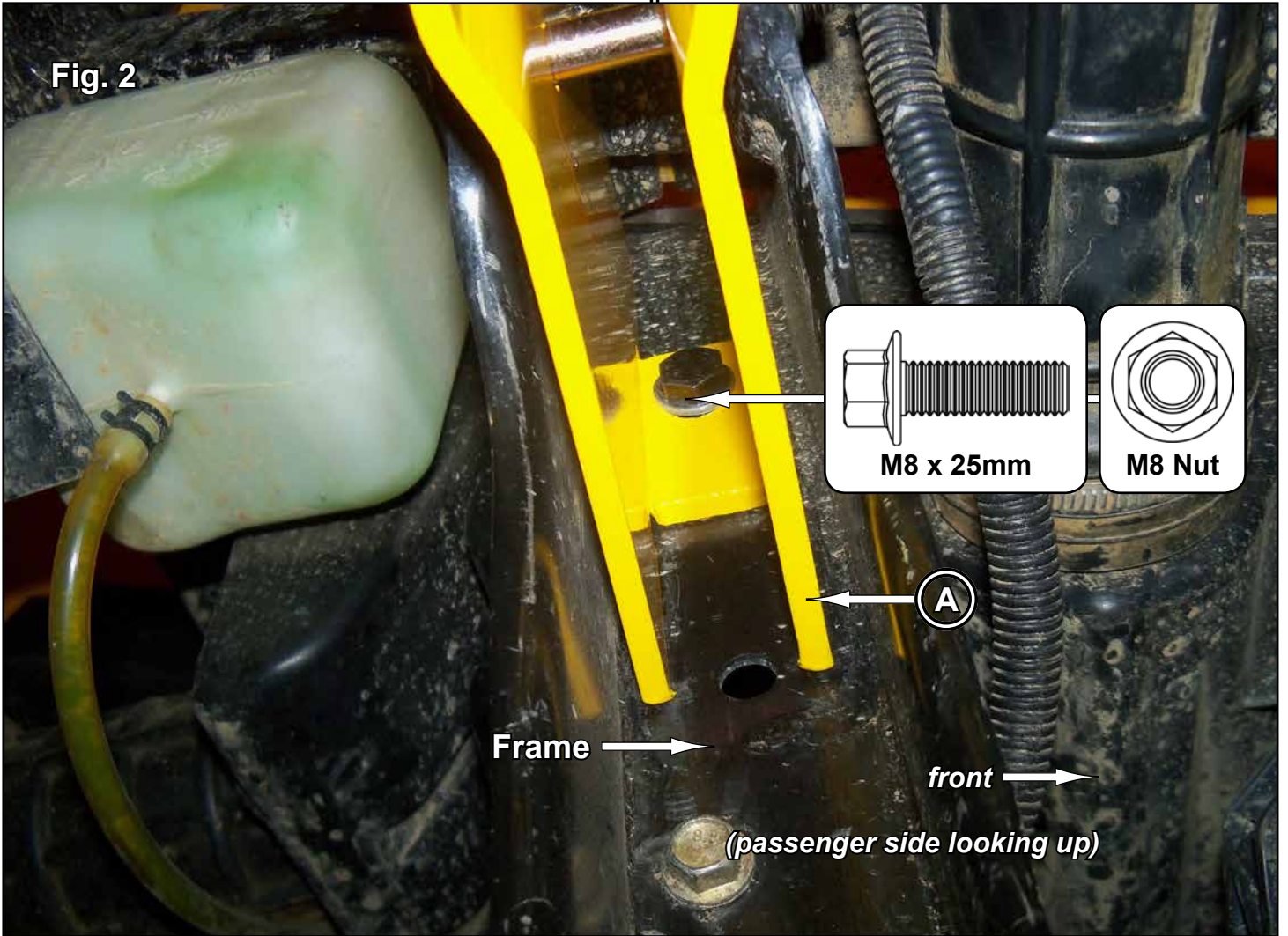
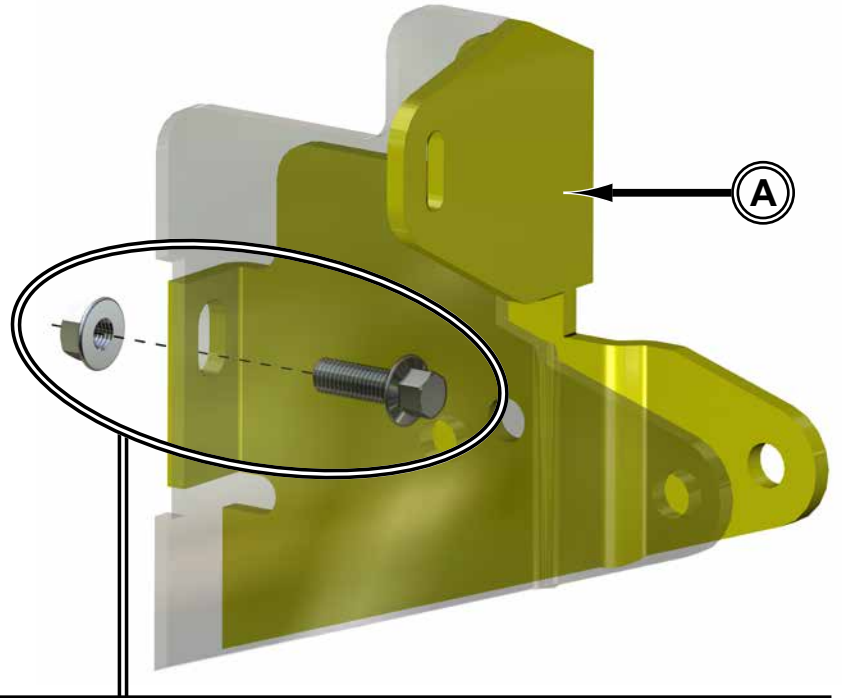

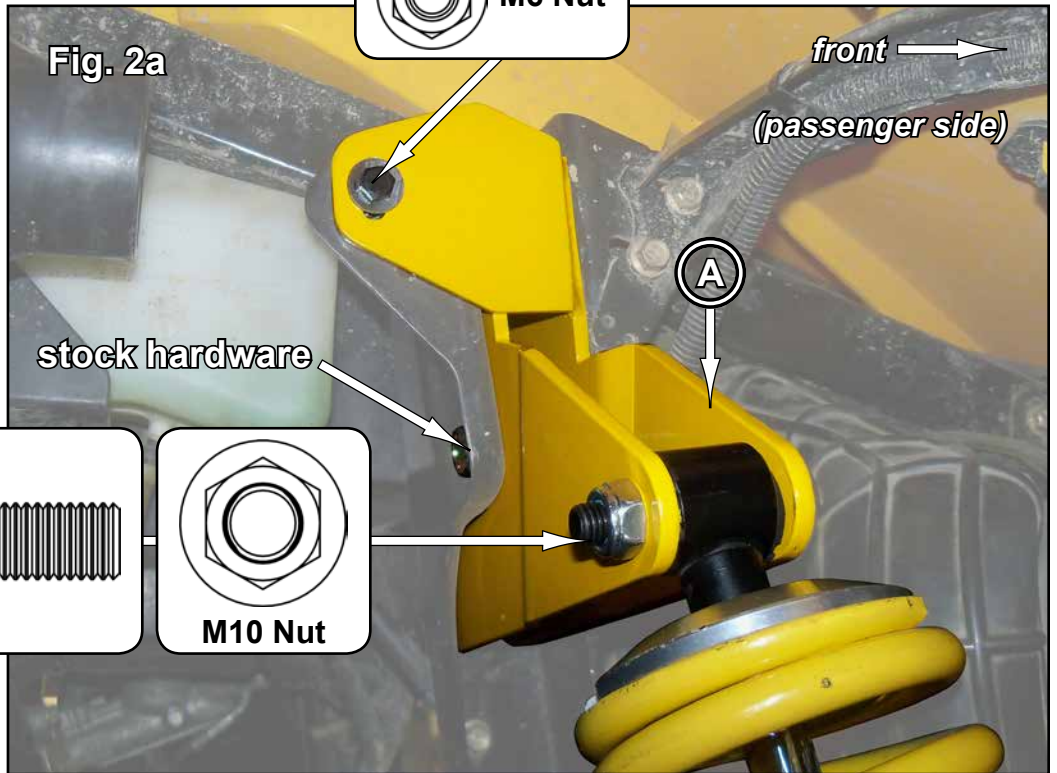
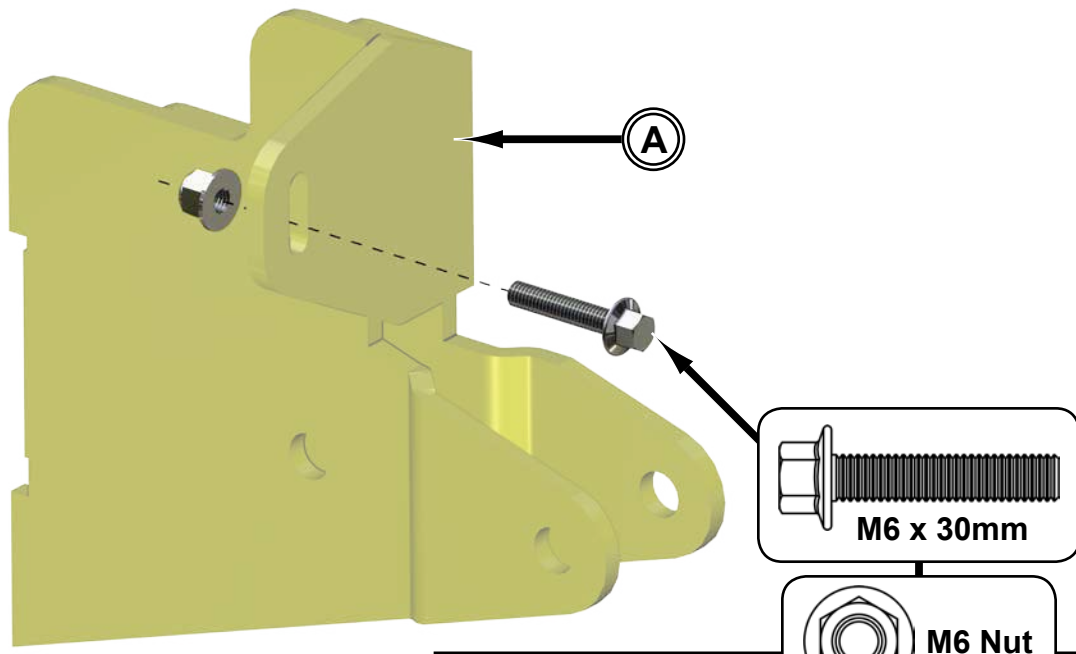

Rear Installation:

1. Raise Cargo Box and remove Bed Stops.
 - Raise rear off ground; secure with jack stands.
 - Remove Wheels.
 - Remove Shocks from Shock Mounts.
2. Install Clip Nuts into stock Shock Mounts. See Figs. 3 - 3b.
3. Install Rear Shock Brackets (C) to stock Shock Mounts; Secure with M8-1.25 x 25mm Lg. FHCS into Clip Nut. See Figs. 3a - 3b.
 - Use M10-1.50 x 70mm Lg. FHCS and M10-1.50 Nylock Nuts to secure Rear Shock Brackets (C) to stock Shock Mount holes. See Figs. 3a - 3b.
4. Reinstall Bed Stops. See Fig. 4.
5. Install Shocks to Rear Shock Brackets (C) with M10-1.50 x 70mm Lg. FHCS and M10-1.50 Nylock Nuts. See Fig. 4.
6. 2014+ years will require Differential Vent Tube rerouting. Reroute and secure to Rear Bracket (C). See last page of instructions.
7. Tighten all hardware completely. Reinstall Wheels.

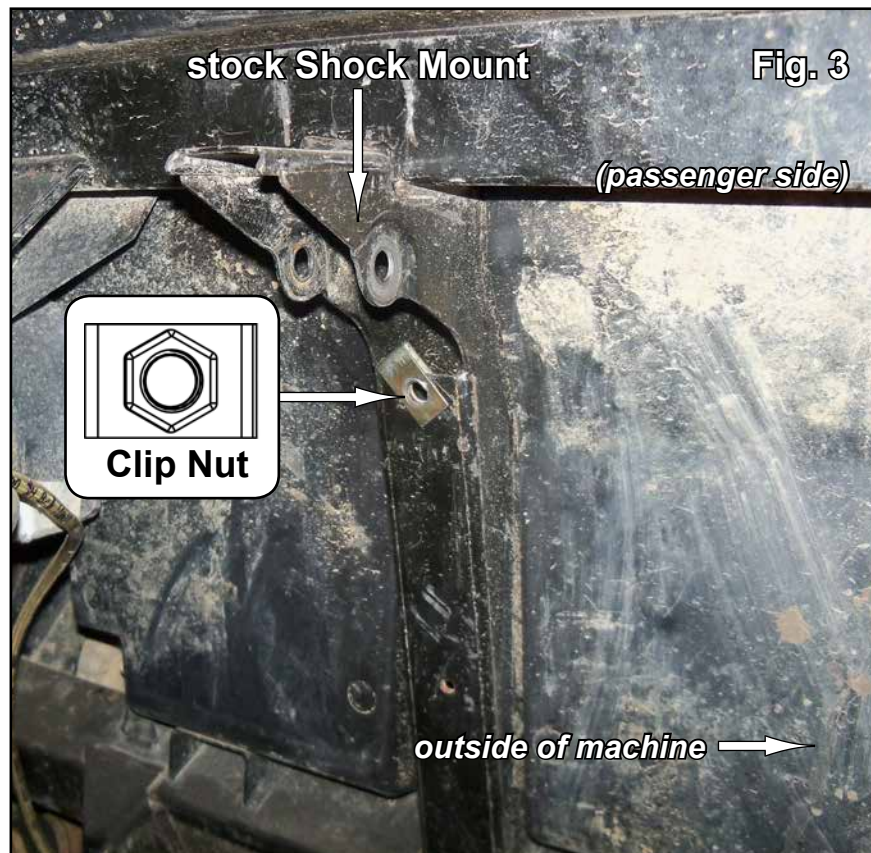

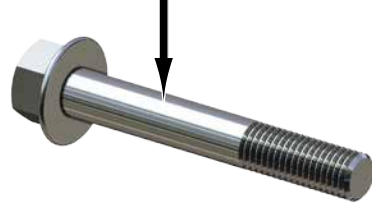
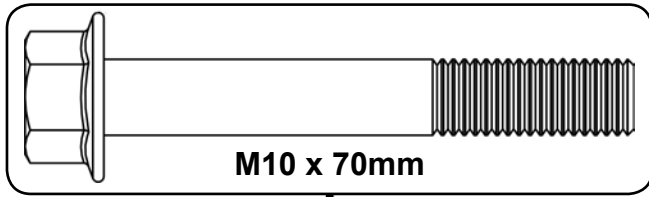
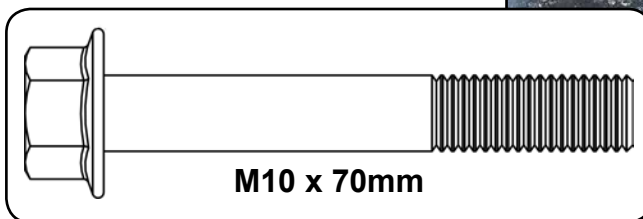
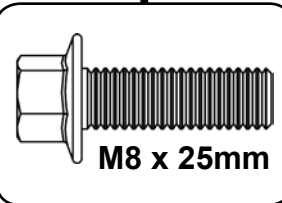
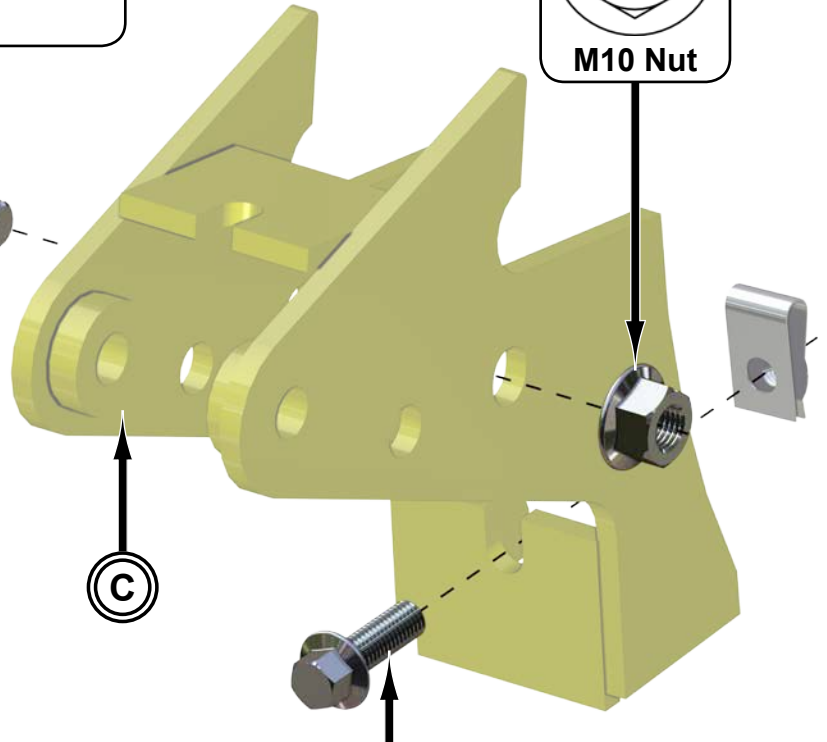
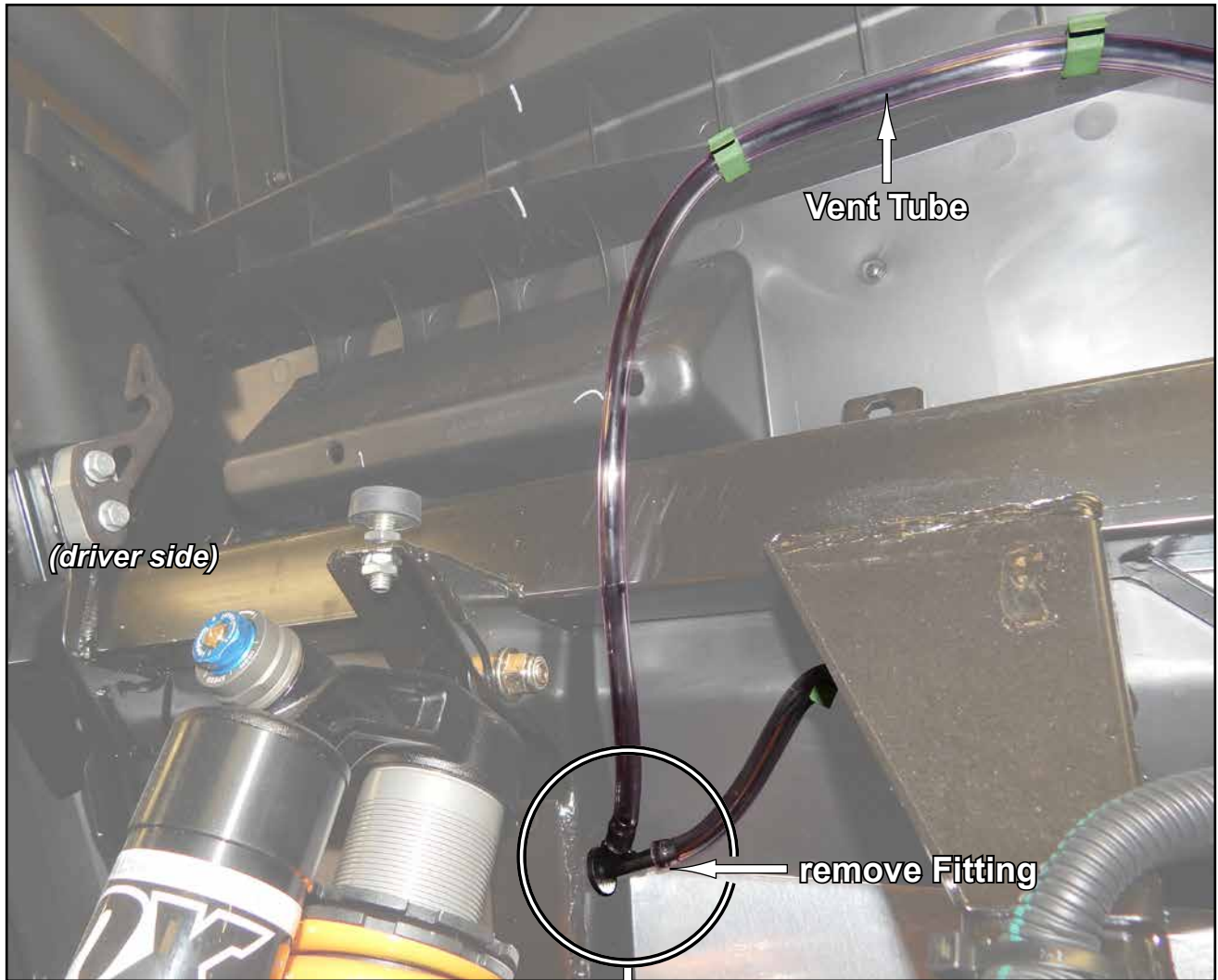

Fig. 3b





Rear Bracket contains mounting location for stock Vent Tube Mounting.
2014+ years will need to reroute and connect.

